

タッチコネクター FUJI スピードコントローラ

TOUCH CONNECTOR FUJI SPEED CONTROLLER



特長

- 回転ロックリングタイプ
チューブの回し(回転)切れを防止
- ネジ部シール加工(Rネジ)
ネジ部シール加工が施されているため、そのまま配管可能
- ネジ上部の自在性
エルボボディーとネジ部は、回転可能
*ロータリータイプではございません。

Main Features

- Compact Size. "Fuji" type touch connection device.
- Chromate treated metal body prevents corrosion.
- Easy to adjust at low flow area. Secure a large free current.
- Easy piping. α -type has a single axis of rotation. This allows the tube to be positioned anywhere along a single plane perpendicular to the body of the controller.
- β -type is designed with two rotational axes. This allows tremendous versatility to position the tube in 3-dimensions.
- In-type has black color nut. Out-Type has yellow color nut.
- Optional color coding for ease of installation and maintenance.
- Compatible with many kinds of tubing. ●Male threads are pre taped with sealant.
- The Lock-ring rotates smoothly in the body and tubing cutting due to the rotation of the tube is prevented.

特長

- 内蔵した接触连接器FUJIの紧凑型設計。
- 有出色的流量特性。可以很容易地在低流量区域作出细微调整。
- 调速器的螺丝上方可以自由旋转,可360°变换方向取出软管。
- 内側/外側旋转类型可用把手的颜色来判断。内側旋转类型为黑色,外側旋转类型为黄色。
- 可以安装分色圈。
- 可以选择软管的材质。
- 密封加工(R螺丝部分)。
- 在内部由具有锁环旋转结构的锁环进行旋转,因此软管不会被转切。

仕様

使用流体	圧縮空気
使用温度範囲	-5~60°C
使用圧力範囲	0.05MPa~0.7MPa
適用チューブ	TE、TP、 MTP (ポリウレタンチューブ)、 TN (ナイロンチューブ)

- *上記の圧力数値は常温時(20°C)に測定したものです。
- *凍結無き事。
- *クリーンエア使用時は弊社までご連絡下さい。

Specifications

Media	Compressed Air
Working Temperature Range	-5~60°C<23~140°F>
Max. Working Pressure	0.05MPa~0.7MPa
Tube used	TE, TP, MTP (Polyurethane tube), TN (Nylon tube)

* The value at a temperature of 20°C(68°F)

规格

使用流体	压缩空气
使用温度范围	-5~60°C
最高使用压力	0.05MPa~0.7MPa
适用管	TE、TP、 MTP (聚氨脂管)、 TN (尼龙管)

* 上述数値是以常温时(20°C)測定的。

主要部品材質 / Materials / 材质

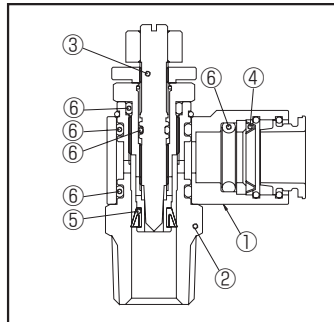

Part NO.	部品名	材質
①	本体 金属部 樹脂部	C3604 (黄銅) ポリアセタール
②	メイルアダプター	C3604 (黄銅)
③	ニードル弁	C3604 (黄銅)
④	ロックリング	リン青銅
⑤	パッキン	ニトリルゴム
⑥	Oリング	ニトリルゴム

Part NO.	Part Name	Materials
①	Main Body Metal Part Plastic part	Brass Polyacetal
②	Male Adaptor	Brass
③	Needle Valve	Brass
④	Lock Ring	Phosphor Bronz
⑤	Packing	NBR
⑥	O-ring	NBR

部品号	部品名	材质
①	本体 金属型 樹脂型	C3604 (黄銅) 聚甲醛
②	樹脂部	C3604 (黄銅)
③	針件适配器	C3604 (黄銅)
④	密封圈	磷青銅
⑤	松放	NBR (丁腈橡胶)
⑥	O型环	NBR (丁腈橡胶)

型式表示例 / How To Order

6 R - 01 SC - 0

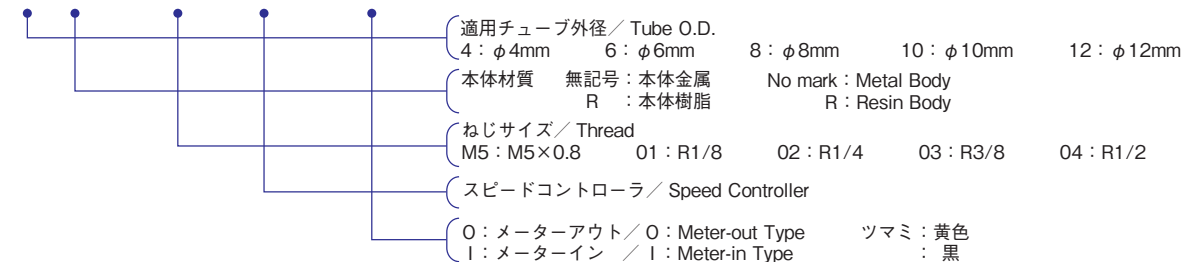

表示マーク凡例 / Symbol Example



タッチコネクター FUJI スピードコントローラ

TOUCH CONNECTOR FUJI SPEED CONTROLLER

スピードコントローラ α [金属] SPEED CONTROLLER α [METAL BODY]

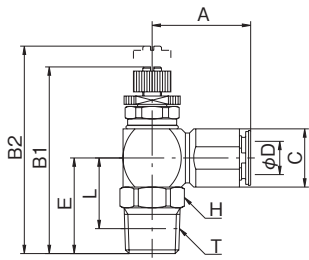

型式 Model		A	B1	B2	C	適用 チューブ 外径 Tube O. D. φD	E	二面幅 Spanner Flats H	L	ねじ サイズ Thread T	チューブ 挿入寸法 Tube Insertion Depth	重量 Weight (g)
メーターアウト Meter-out	メーターイン Meter-in											
4-M5SC-0	4-M5SC-I	20.6	35.7	38.9	φ11.0	4	15.5	12.0	12.5	M5×0.8	15.0	28.0
4-01SC-0	4-01SC-I	20.6	39.2	42.4	φ11.0	4	19.0	12.0	15.0	R1/8	15.0	30.5
6-M5SC-0	6-M5SC-I	21.7	35.7	38.9	12.0	6	15.5	12.0	12.5	M5×0.8	16.3	29.5
6-01SC-0	6-01SC-I	21.7	39.2	42.4	12.0	6	19.0	12.0	15.0	R1/8	16.3	32.0
6-02SC-0	6-02SC-I	21.7	42.2	45.4	12.0	6	22.0	14.0	16.0	R1/4	16.3	37.5
8-01SC-0	8-01SC-I	23.7	41.9	47.0	14.0	8	20.0	14.0	16.0	R1/8	17.0	44.0
8-02SC-0	8-02SC-I	23.7	44.9	50.0	14.0	8	23.0	14.0	17.0	R1/4	17.0	48.5
8-03SC-0	8-03SC-I	23.7	45.9	51.0	14.0	8	24.0	17.0	17.6	R3/8	17.0	56.5
10-02SC-0	10-02SC-I	26.6	48.2	54.5	17.0	10	24.5	17.0	18.5	R1/4	17.8	74.0
10-03SC-0	10-03SC-I	26.6	49.2	55.5	17.0	10	25.5	17.0	19.1	R3/8	17.8	81.0
10-04SC-0	10-04SC-I	26.6	53.2	59.5	17.0	10	29.5	21.0	21.5	R1/2	17.8	99.0
12-03SC-0	12-03SC-I	29.1	52.1	61.2	19.0	12	26.5	19.0	20.1	R3/8	19.4	105.0
12-04SC-0	12-04SC-I	29.1	56.1	65.2	19.0	12	30.5	21.0	22.5	R1/2	19.4	123.0

メーターアウトタイプ METER-OUT TYPE

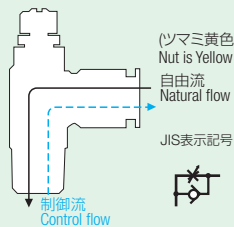

メーターインタイプ METER-IN TYPE

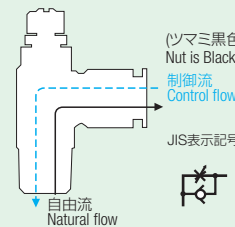

スピードコントローラ α [樹脂] SPEED CONTROLLER α [RESIN BODY]

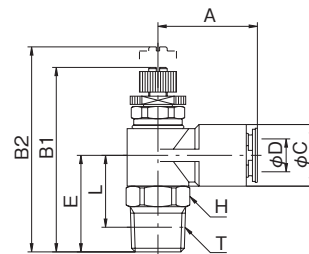

型式 Model		A	B1	B2	φC	適用 チューブ 外径 Tube O. D. φD	E	二面幅 Spanner Flats H	L	ねじ サイズ Thread T	チューブ 挿入寸法 Tube Insertion Depth	重量 Weight (g)
メーターアウト Meter-out	メーターイン Meter-in											
6R-M5SC-0	6R-M5SC-I	21.7	35.7	38.9	13.0	6	16.0	12.0	13.0	M5x0.8	16.3	20.0
6R-01SC-0	6R-01SC-I	21.7	39.2	42.4	13.0	6	19.5	12.0	15.5	R1/8	16.3	22.0
6R-02SC-0	6R-02SC-I	21.7	42.2	45.4	13.0	6	22.5	14.0	16.5	R1/4	16.3	27.5
8R-01SC-0	8R-01SC-I	24.2	41.9	47.0	15.0	8	20.5	14.0	16.5	R1/8	17.5	30.5
8R-02SC-0	8R-02SC-I	24.2	44.9	50.0	15.0	8	23.5	14.0	17.5	R1/4	17.5	35.5
8R-03SC-0	8R-03SC-I	24.2	45.9	51.0	15.0	8	24.5	17.0	18.1	R3/8	17.5	43.0
10R-02SC-0	10R-02SC-I	26.6	48.2	54.5	17.0	10	24.5	17.0	18.5	R1/4	18.3	51.0
10R-03SC-0	10R-03SC-I	26.6	49.2	55.5	17.0	10	25.5	17.0	19.1	R3/8	18.3	58.0
10R-04SC-0	10R-04SC-I	26.6	53.2	59.5	17.0	10	29.5	21.0	21.5	R1/2	18.3	76.0
12R-03SC-0	12R-03SC-I	29.1	52.1	61.2	20.0	12	27.0	19.0	20.6	R3/8	19.4	75.0
12R-04SC-0	12R-04SC-I	29.1	56.1	65.2	20.0	12	31.0	21.0	23.0	R1/2	19.4	93.0

メーターアウトタイプ METER-OUT TYPE

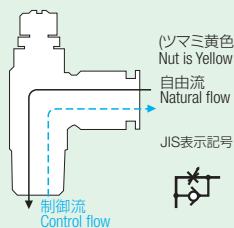

メーターインタイプ METER-IN TYPE

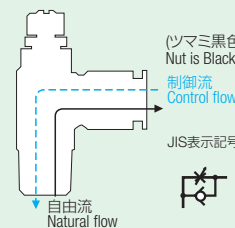

※上記に表示されていない単位は全てmm

タッチコネクター FUJI スピードコントローラ

TOUCH CONNECTOR FUJI SPEED CONTROLLER

スピードコントローラ β [金属] SPEED CONTROLLER β [METAL BODY]

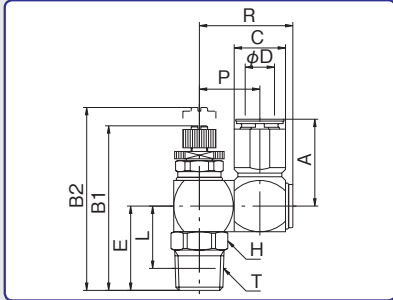

型式 Model		A	B1	B2	C	適用 チューブ 外径 Tube O. D. φD	E	二面幅 Spanner Flats H	L	P	R	ねじ サイズ Thread T	チューブ 挿入寸法 Tube Insertion Depth	重量 Weight (g)
メーターアウト Meter-out	メーターイン Meter-in													
B4-M5SC-0	B4-M5SC-I	20.6	35.7	38.9	φ11.0	4	15.5	12.0	12.5	14.0	22.0	M5×0.8	15.0	42.0
B4-01SC-0	B4-01SC-I	20.6	39.2	42.4	φ11.0	4	19.0	12.0	15.0	14.0	22.0	R1/8	15.0	44.5
B6-M5SC-0	B6-M5SC-I	21.7	35.7	38.9	12.0	6	15.5	12.0	12.5	14.0	22.0	M5×0.8	16.3	43.5
B6-01SC-0	B6-01SC-I	21.7	39.2	42.4	12.0	6	19.0	12.0	15.0	14.0	22.0	R1/8	16.3	45.5
B6-02SC-0	B6-02SC-I	21.7	42.2	45.4	12.0	6	22.0	14.0	16.0	14.0	22.0	R1/4	16.3	51.5
B8-01SC-0	B8-01SC-I	23.7	41.9	47.0	14.0	8	20.0	14.0	16.0	16.5	25.5	R1/8	17.0	65.5
B8-02SC-0	B8-02SC-I	23.7	44.9	50.0	14.0	8	23.0	14.0	17.0	16.5	25.5	R1/4	17.0	70.5
B8-03SC-0	B8-03SC-I	23.7	45.9	51.0	14.0	8	24.0	17.0	17.6	16.5	25.5	R3/8	17.0	78.0
B10-02SC-0	B10-02SC-I	26.6	48.2	54.5	17.0	10	24.5	17.0	18.5	20.2	30.9	R1/4	17.8	112.5
B10-03SC-0	B10-03SC-I	26.6	49.2	55.5	17.0	10	25.5	17.0	19.1	20.2	30.9	R3/8	17.8	119.0
B10-04SC-0	B10-04SC-I	26.6	53.2	59.5	17.0	10	29.5	21.0	21.5	20.2	30.9	R1/2	17.8	137.0
B12-03SC-0	B12-03SC-I	29.1	52.1	61.2	19.0	12	26.5	19.0	20.1	21.2	32.9	R3/8	19.4	153.5
B12-04SC-0	B12-04SC-I	29.1	56.1	65.2	19.0	12	30.5	21.0	22.5	21.2	32.9	R1/2	19.4	171.5

メーターアウトタイプ METER-OUT TYPE

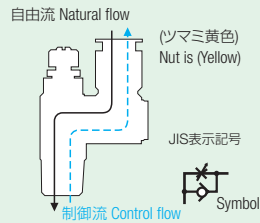

メーターインタイプ METER-IN TYPE

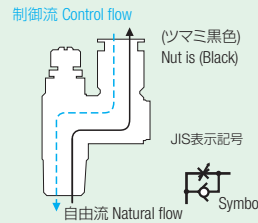

スピードコントローラ β [樹脂] SPEED CONTROLLER β [RESIN BODY]

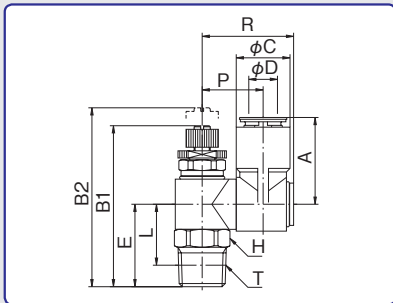

型式 Model		A	B1	B2	φC	適用 チューブ 外径 Tube O. D. φD	E	二面幅 Spanner Flats H	L	P	R	ねじ サイズ Thread T	チューブ 挿入寸法 Tube Insertion Depth	重量 Weight (g)
メーターアウト Meter-out	メーターイン Meter-in													
B6R-M5SC-0	B6R-M5SC-I	21.7	35.7	38.9	13.0	6	15.5	12.0	12.5	14.5	22.0	M5×0.8	16.3	22.5
B6R-01SC-0	B6R-01SC-I	21.7	39.2	42.4	13.0	6	19.0	12.0	15.0	14.5	22.0	R1/8	16.3	25.0
B6R-02SC-0	B6R-02SC-I	21.7	42.2	45.4	13.0	6	22.0	14.0	16.0	14.5	22.0	R1/4	16.3	30.5
B8R-01SC-0	B8R-01SC-I	24.2	41.9	47.0	15.0	8	20.0	14.0	16.0	17.0	25.5	R1/8	17.5	34.5
B8R-02SC-0	B8R-02SC-I	24.2	44.9	50.0	15.0	8	23.0	14.0	17.0	17.0	25.5	R1/4	17.5	39.5
B8R-03SC-0	B8R-03SC-I	24.2	45.9	51.0	15.0	8	24.0	17.0	17.6	17.0	25.5	R3/8	17.5	47.5
B10R-02SC-0	B10R-02SC-I	26.6	48.2	54.5	17.0	10	24.5	17.0	18.5	20.2	30.9	R1/4	18.3	58.5
B10R-03SC-0	B10R-03SC-I	26.6	49.2	55.5	17.0	10	25.5	17.0	19.1	20.2	30.9	R3/8	18.3	65.0
B10R-04SC-0	B10R-04SC-I	26.6	53.2	59.5	17.0	10	29.5	21.0	21.5	20.2	30.9	R1/2	18.3	83.5
B12R-03SC-0	B12R-03SC-I	29.1	52.1	61.2	20.0	12	26.5	19.0	20.1	21.7	32.9	R3/8	19.4	85.5
B12R-04SC-0	B12R-04SC-I	29.1	56.1	65.2	20.0	12	30.5	21.0	22.5	21.7	32.9	R1/2	19.4	103.5

メーターアウトタイプ METER-OUT TYPE

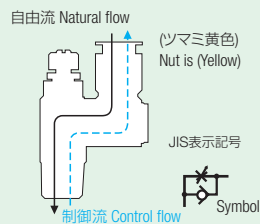

メーターインタイプ METER-IN TYPE

